

OFFICIAL WRESTLING GUIDE

OFFICIAL

Intercollegiate and Interscholastic

1964 WRESTLING RULES

1961-62 NCAA Wrestling Rules Committee

JOHN W. HANCOCK, <i>Chairman</i>	Colorado State College
RALPH G. ANDERTON	Brown
CASEY L. FREDERICKS	Ohio State
JOHN H. GUITON	Citadel
M. BRIGGS HUNT	U.C.L.A.
WILLIAM KOLL	Iowa State College
GERALD LEEMAN	Lehigh
HAROLD J. NICHOLS	Iowa State University
CLAUDE REECK	Purdue
FRED B. ROBY	Arizona
ERWIN R. SNAVELY	DePauw
*FYNN B. ERIKSEN	Waterloo Public Schools, Ia.
*JOHN E. ROBERTS	Wisconsin Interscholastic AA

*Appointed to the Committee by the Executive Committee of the National Federation of State High School Athletic Assns.

CHARLES W. PARKER, EDITOR

Major Rules Changes

Rule 3, Costumes—New Sentence added—AT NCAA Championship Tournaments shirts are mandatory and must be worn at all times.

Rule 5, New Section 9 Added—Any contestant who fails to check in or to make weight each day of a tournament is ineligible for further competition and cannot place in the tournament.

Rule 8—Referee's Position changed to allow offensive wrestler to move his legs back as long as he stays outside the line of the near leg.

Rule 8, Definitions—Fall—Now changed to one second controlled fall. Predicament and Near-Fall changed to control and not dependent on a pinning combination.

Rule 10, Infractions—Holding Legs—Considered as stalling and requires warning.

Rule 10, Stalling—Defensive Position—When there is no action in the mat position, the responsibility for initiating action rests with the defensive wrestler.

Rule 10, Grasping Clothing, etc.—Penalty for technical violation shall be treated the same as locked hands—Under Note Interlocking of Hands.



NCAA WRESTLING RULES COMMITTEE: Left to right, front row—Finn Eriksen (Waterloo Public Schools), John Guiton (Citadel), John Hancock (Colorado State College) Chairman, Harold Nichols (Iowa State U.), Casey Fredericks (Ohio State), Briggs Hunt (UCLA); back row—Gerald Leeman (Lehigh), Bill Koll (Iowa State College), John Roberts (Wisconsin IAA), Fred Roby (Arizona), Claude Reeck (Purdue), Edwin Snavely (De-Pauw), Ralph Anderson (Brown).

Official NCAA Wrestling Rules

RULE I—ELIGIBILITY

SECTION 1. Each contestant must be an Amateur as defined in the rules of the National Collegiate Athletic Association and be eligible according to the rules and regulations of the college or university which he represents. Participants in the National Collegiate Wrestling Championships must represent institutions which are active members of the NCAA in good standing and must conform to the rules of eligibility adopted by the NCAA to apply to all annual championship meets conducted by this Association.

Note—See Rule 5, Section 4.

SECTION 2. All colleges, universities and institutions of learning in the United States with acceptable scholastic and athletic standards may be elected to membership in the NCAA. To comply with "acceptable scholastic standards" the institution must be on the approved list of the accepted accrediting agency of the district in which the institution is located.

SECTION 3. An institution is considered as having "satisfactory athletic standards" on approval of its standards by a two-thirds majority of the active members of the NCAA in the Association District in which the institution is located. Further information regarding application for membership may be obtained from the Executive Director of the NCAA, Walter Byers, 206 Fairfax Building, Kansas City 5, Mo. At least thirty (30) days should be allowed for the above procedure.

RULE II—REPRESENTATION

SECTION 1. An institution shall be represented by only one contestant in each weight class.

SECTION 2. No contestant shall be allowed to represent his institution in more than one class in each meet.

SECTION 3. A representative may not accept a forfeit in one weight class and compete in another class.

SECTION 4. A contestant who weighs-in for one weight may be shifted to a higher weight class.

National Collegiate Championships SECTION 5. All entries to the National Collegiate Wrestling Championships which are received after the deadline date shall be charged a double entry fee. The deadline shall be nine days in advance of the first tournament session. When the team registers at the National Championships the institutional representative shall indicate the entry in each weight class in so far as it is possible before the weighing-in.

RULE III—MATS, COSTUMES AND EQUIPMENT

Mats SECTION 1. The wrestling area of the mat shall not be less than a square 24 feet by 24 feet. There shall be a mat area at least 5 feet in width which extends entirely around the wrestling area. The entire mat area shall be the same thickness which shall not be more than 4 inches nor less than the thickness of a mat which has the shock absorbing qualities of a 2-inch thick hair felt mat.

It is recommended that a plastic mat cover be provided sufficiently large to cover the mat proper and all supplementary mats. This cover should be stretched tightly and be held in place by ropes, or tape fastening the mat cover to the under side of the supplementary mats, or by lacing the cover underneath the mats. The wrestling area should be marked on the mat cover or mat by painted lines two inches in width. At the center of the mat proper there shall be similarly painted a circle ten feet in diameter. Whenever the match is started or resumed, the contestants shall be opposite each other on the 10-foot circle and throughout the match contestants are expected to wrestle within this circle so far as possible. There shall be placed at the center of the cover a design, at least twelve inches long, perpendicular to and pointing away from the timer's table. This design designates the place where matches are to start and the direction wrestlers are to face when starting the wrestling from the referee's position on the mat.

Costume SECTION 2. The costume shall consist of:

a. Full length tights and close fitting outside short trunks. Trunks may be worn without the tights if they are fitted so as to prevent unseemly exposure, however, full length tights and close covering sleeveless shirts are recommended. When trunks are worn without tights, shirts shall be required. The one piece uniform is illegal for interscholastic, intercollegiate and NCAA competition. At NCAA Championship Tournaments shirts are mandatory and must be worn at all times.

b. Light heelless gymnasium shoes reaching above the ankle and laced by means of eyelets.

c. Shirts, if required by the home management. The shirt shall be sleeveless without fasteners at the shoulder and fastened down at the crotch. They shall not be cut away in excess of the shirt illustrated in Figures 1 and 2 (picture of legal shirt, back and front view). The visiting team must be

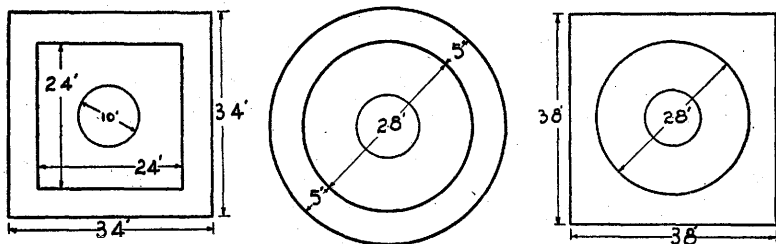

MINIMUM MAT SIZES

A circle with a diameter of 28 feet is a legal wrestling area providing there is a mat area at least 5 feet in width which extends around it.

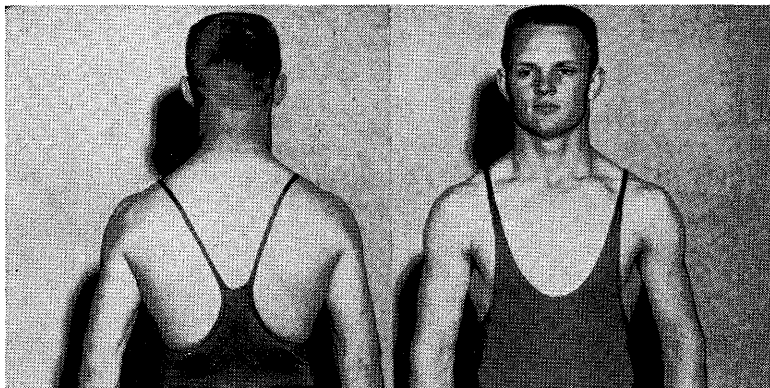

Nos. 1 and 2 FRONT AND REAR VIEW OF SHIRT

This shows front and rear view official shirt. Any shirt with more exposure is illegal.

notified in sufficient time to be able to comply with the home team's request. (See Rule 14, Section 3.)

d. It happens occasionally that two contestants look so much alike and are dressed so similarly that it is very difficult for the Referee and spectators to distinguish them. In all dual meets or tournaments, the home management shall have immediately available some provisions for clearly identifying the contestants. Such provisions may be by means of colored anklets, numbers or any other plan which will accomplish the purpose.

Headgears SECTION 3. The Rules Committee strongly recommends that protective headgear be used in all practice and competition.

Special Equipment SECTION 4. Any mechanical device, which does not allow normal movement of the joints and prevents one's opponent from applying normal holds shall be barred. Any legal device which is hard and abrasive must be covered and padded. Loose pads are prohibited.

Enforcement SECTION 5. The legality of all equipment (mats, costumes, helmets, devices, pads, etc.) shall be decided by the referee.

RULE IV—WEIGHT CLASSIFICATION

(ALSO SEE HIGH SCHOOL WEIGHTS—PAGE 91)

SECTION 1. Competition shall be divided into eight weight classes as follows:

123 lbs.	137 lbs.	157 lbs.	177 lbs.
130 lbs.	147 lbs.	167 lbs.	Unlimited

The 115-lb. and/or 191-lb. classes may be officially included in the weight classification provided either or both are adopted by individual conferences. Interconference meets shall be contested in the original (8) weights.

For the National Collegiate Wrestling Championships the 115 and 191-lb. classes will be included. These weights will count in the scoring of the team championship.

Competition in dual meets shall be conducted in the weight order listed, unless changes are mutually agreed upon at the time of weigh-in.

RULE V—WEIGHING-IN AND DESIGNATION OF CONTESTANTS

Time SECTION 1. *a. Tournaments.* Each day of the tournament, except the first day, contestants will weigh-in a maximum of five hours and a minimum of four hours before the meet is scheduled to begin.

For the first day of the National Collegiate Wrestling Championships contestants will weigh-in a maximum of six hours and a minimum of five hours before the meet is scheduled to begin.

b. The contestant who is to represent his institution must be named at the time of weigh-in in all tournaments.

c. Dual Meets. Contestants may weigh-in a maximum of five hours and a minimum of one-half hour before the meet is scheduled to begin. The exact maximum time shall be decided by mutual agreement of the competing teams. The home team's representative shall be sent onto the mat first, and he cannot be withdrawn or replaced.

b. Supervision. The Referee or other authorized person shall supervise the weighing-in of contestants.

e. Teams may weigh-in on home scales by mutual agreement of coaches and shall furnish the weight list with actual weights listed. It is recommended that the accuracy of all scales be certified by a qualified scale authority.

Weight Allowance SECTION 2. *a. Dual Meets.* In all dual meets, net weights shall be required. No overweight is permitted nor should it be requested.

b. Tournaments. In tournaments a one pound allowance shall be given each day over the weight limit of the previous day.

Failure to Make Weight SECTION 3. Any contestant failing to make weight at the minimum time shall be rejected. If a contestant fails to weigh-in on the second or subsequent day a forfeit shall be awarded his opponent and points for the forfeit and advancement shall be scored.

Medical Examinations SECTION 4. At the time of the weighing-in on the opening day of the annual National Collegiate Championships, a physician or physicians shall be present to examine all contestants for communicable diseases and shall disqualify any contestant who, in their judgment, will endanger other participants. In other meets it is recommended that a medical examination of all contestants be made at the time of the weighing, in, and the presence of a communicable disease or any other condition, which in the opinion of the examining physician makes the participation of that individual inadvisable, should be considered full and sufficient reason for disqualification.

SECTION 5. No substitution is allowed in dual meets or tournaments for injured contestants.

SECTION 6. Defeat due to injury in a tournament does not eliminate a man for third place competition.

SECTION 7. A forfeit will eliminate a contestant from third place competition in tournaments.

SECTION 8. A disqualification may eliminate a contestant from third place competition in tournaments. (See note under penalty chart.)

SECTION 9. Any contestant who fails to check in or to make weight each day of a tournament is ineligible for further competition and cannot place in the tournament.

Note—In case of unavoidable circumstances affecting weigh-in or schedule of matches, see Rule 13, Section 15.

RULE VI—CONDUCT OF TOURNAMENTS

Places Scored **SECTION 1.** In all tournaments four places shall be awarded as follows: The loser in the final first place match shall automatically take second place; the winner of the final consolation match shall be awarded third place and the loser fourth place.

Note—In the National Collegiate Championships tournament six places shall be awarded (see Rule 9, Sec. 1a).

Drawings **SECTION 2.** Immediately after the expiration of the minimum weighing-in time, drawings shall be made. Drawings shall be made in accordance with the graphic illustrations as provided in Sections 5, 6 and 7 of this rule.

Seeding **SECTION 3.** Whenever there are two outstanding contestants in any class, the name of one of these contestants shall be placed in the upper half of the drawing bracket and the name of the other in the lower half. In case several seeded men are of equal ability, their seeded positions shall be determined by drawing.

If there is one outstanding wrestler in any class and also two others who are distinctly superior to the remainder in that class, those wrestlers should be seeded in different quarter brackets of the opposite half bracket from the outstanding wrestler. A seeded contestant shall have the same opportunity to draw for the bye as other contestants in his bracket.

In the annual National Collegiate Championships, whenever possible, contestants from the same geographical location or conference who have previously met during the season shall be drawn so as to prevent them from meeting in the first round.

Byes **SECTION 4.** When the number of competitors is not a power of two (that is, 4, 8, 16, 32, 64) there shall be "byes" in the first round. The number of pairs which meet in the first round shall be equal to the difference between the number of competitors and the next lower power of two. There will be no byes after the first round and no further drawing is necessary for the first place or consolation rounds. The byes, if even in number, shall be equally divided between top and bottom. If the number of byes be uneven, there shall be one more bye at the bottom than at the top, as shown in Section 5 of this rule.

Any conference or other tournament may be conducted under any bracketing that is agreed upon by the participating schools.

SECTION 5. Graphic Illustration of Drawings and Seeding.

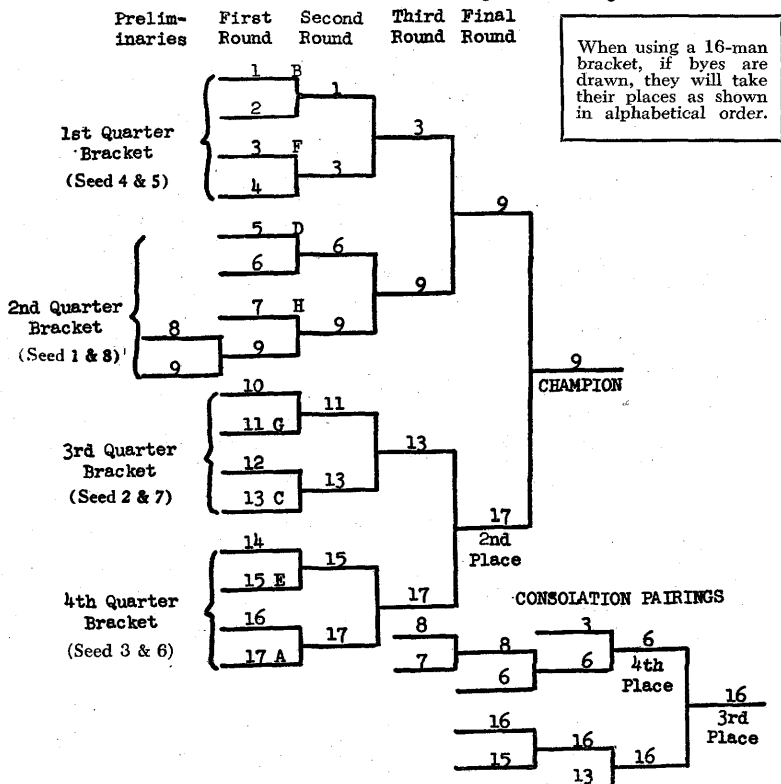

Number 1 seeded man draws for possible positions 5, 6, 7, 8, 9, in 2nd Quarter Bracket.

Number 2 seeded man draws for possible positions 10, 11, 12, 13, in 3rd Quarter Bracket.

Number 3 seeded man draws for possible positions 14, 15, 16, 17, in 4th Quarter Bracket.

Number 4 seeded man draws for possible positions 1, 2, 3, 4, in 1st Quarter Bracket.

Number 5 seeded man draws for position in opposite half of Quarter Bracket #1.

Number 6 seeded man draws for position in opposite half of Quarter Bracket #4.

Number 7 seeded man draws for position in opposite half of Quarter Bracket #3.

Number 8 seeded man draws for position in opposite half of Quarter Bracket #2.

Contestants Eligible for Third Place Matches

by the winner of this semi-final match. (See b following.)

After completion of the second semi-final match in this same weight the

SECTION 6. a. Immediately after completion of the first semi-final match in each weight the third place consolation rounds shall start between all contestants defeated

same plan shall be followed as indicated in the preceding paragraph. The winners of the third place consolation rounds in each of the two half-brackets in each weight class, meet in the final consolation match to determine the third and fourth place winner.

b. When only two contestants have been defeated by the winner of any semi-final match the two defeated contestants shall compete and the winner of the match shall meet the corresponding winner from the other half-bracket to decide the third and fourth place awards. When more than two contestants have been defeated by the winner of any semi-final match, preliminary third place matches will be necessary and *should be conducted in accordance with the original first round drawings*; therefore, those eligible for the third place consolations should be matched in the order in which they were defeated by the finalists in this half-bracket. The eligible contestants are designated in Section 6a of this Rule.

Example

SECTION 7. Referring to the Graphic Illustration under Section 5, those eligible for the third place rounds in the upper half-bracket 8, 7, 6, 3, we will assume that 8 wins from 7 and then 6 wins from 8 and 6 defeats 3.

In the lower half-bracket three contestants 16, 15 and 13 have been defeated by the finalist 17 and therefore, only two matches are necessary. We will assume 16 defeats 15 and later defeats 13. He meets 6 in the final consolation match in this weight. The winner 16 is awarded third place and the loser 6 fourth place. All third place matches shall be run off prior to the first place finals matches.

SECTION 8. No contestant shall be required to wrestle two matches in any tournament with less than one (1) hour rest between such matches.

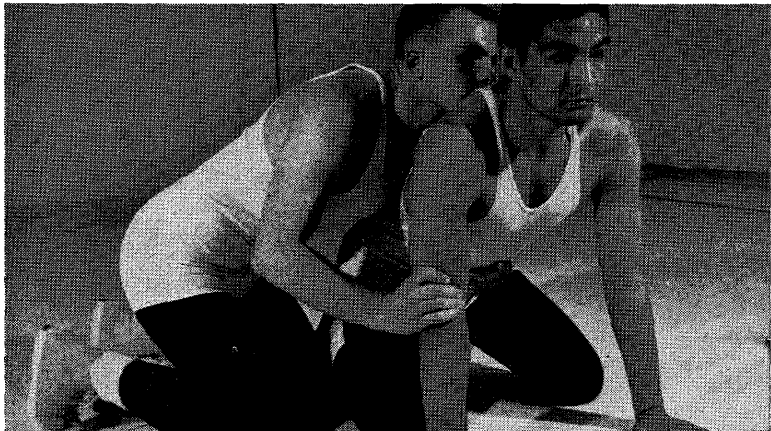

No. 3—LEGAL "REFEREE'S POSITION ON MAT"

This position is shown as required in Rule 8, Section 1, a and b. Note particularly that offensive wrestler's leg is outside of defensive wrestler's leg.

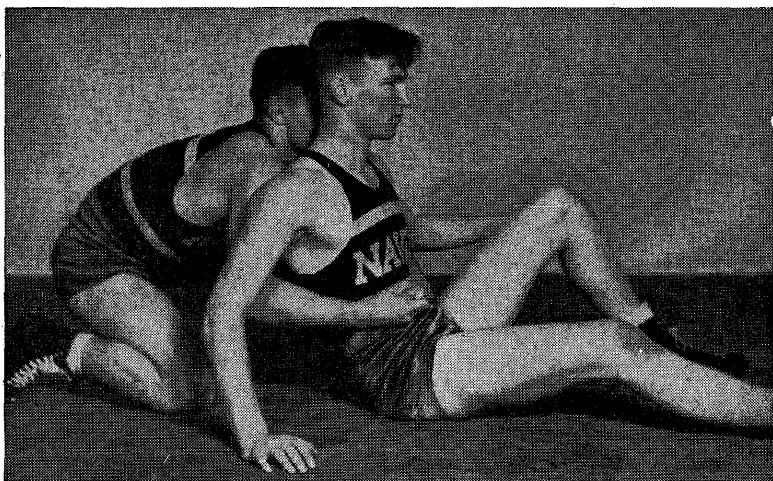

No. 4—INTERLOCKING OF HANDS AROUND THE BODY—A Technical Violation
Offensive wrestler is not allowed to lock hands, wrists or arms around body while defensive wrestler is supported by parts other than his feet.

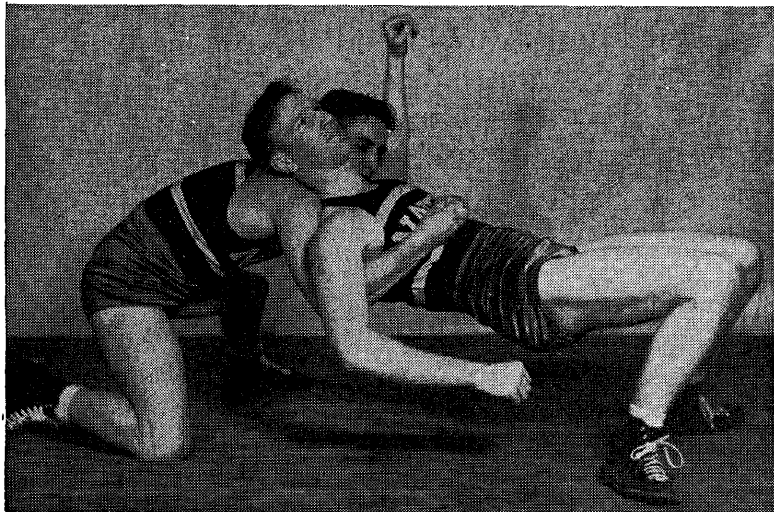

No. 5—LEGAL USE OF THE HANDS IN WAISTLOCK
This shows the legal use of the hands of the top man. The defensive contestant's supporting parts except feet are clearly off the mat.

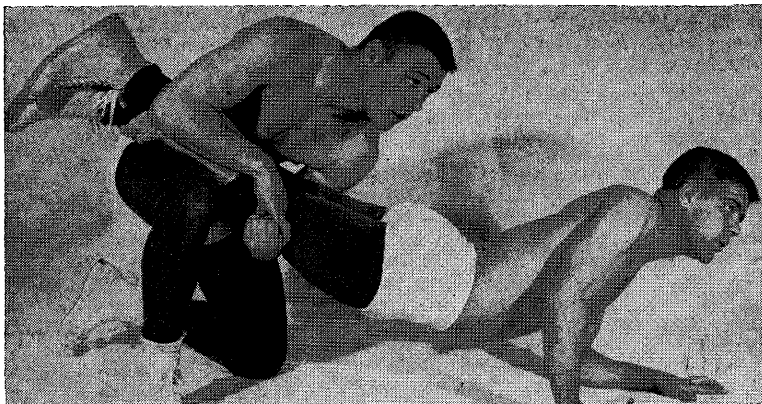

No. 6—INTERLOCKING OF HANDS AROUND LEGS
This position is a technical violation

SECTION 9. The Wrestling Rules Committee recommends that medals and team trophies be formally presented in a ceremony made as impressive as possible.

RULE VII—CONDUCT OF MATCHES

SECTION 1. All regular matches shall consist of three three-minute periods. The first period will start with both contestants standing opposite each other and on the 10-foot circle. The wrestlers will come forward, shake hands with the right hand, pass each other, turn to the left at the edge of the circle and, when the Referee blows his whistle, begin wrestling. A fall during this or either subsequent period terminates the match. If neither contestant secures a fall in this first period, the Referee shall recess the match and place the wrestlers in the Referee's position (Rule 8, Section 1) with the appropriate contestant in the position of advantage (Rule 7, Section 3). The second three-minute period shall be started immediately by the Referee's whistle. If no fall occurs during this second period, upon its expiration the Referee shall again recess the match, place the contestant who started the second period in the position of advantage underneath and start the third period as before. If no fall occurs during this final period, upon termination of the match the Referee shall award the contest as provided (Rule 8, Section 14 and Rule 7, Section 4). The time in a match is continuous except when the Referee stops and starts a match.

Intermission SECTION 2. Each recess between the periods of any match shall be only such time as is required by the Referee to bring the contestants into the proper position for the next period. No rest shall be permitted except for injury. (See Rule 12, Section 1.)

Choice of Position SECTION 3. *a. Dual Meets.* Immediately before the contest starts the Referee shall call the captains to the center of the mat and decide by the toss of a coin which team has the choice of

position at the start of the second period in each weight class. The winner of a toss may choose the odd or even weight class. A choice of odd or even matches in dual meets is not altered in case of a fall, default or forfeit.

b. Tournament. Immediately following the end of the first period the Referee shall determine which wrestler has the choice of position at the start of the second period, by the toss of a coin or disk.

SECTION 4. Overtimes. In tournament competition when there is a tie in points the contestants shall wrestle two extra periods of two minutes each (consolation matches, two periods of one minute each) starting from the referee's position as in the second and third periods of the regular match. The choice of position shall be determined by the toss of a coin. There shall be one-minute rest between the regular match and the first overtime period and no rest between the first and second overtime periods. The points and time advantage are not cumulative throughout the match and overtime periods, and only the points and time advantages scored in the overtime period shall be counted in determining the winner. A jury of two judges and the referee shall observe the overtime periods. When there is a tie in points at the end of the overtime periods the jury shall select the winner by ballot without any consultation and the match shall be awarded to the contestant who has shown superior wrestling ability in the overtime periods. The signed ballots of the jury shall be recorded on the score sheet. The criteria for determining superior wrestling ability are attempts to secure falls, take-downs, reversals, and escapes along with the maintenance of control.

Note—See Rule 11, Section 3.

**Consolation
Matches**

SECTION 5. Consolation matches shall consist of three two-minute periods conducted in the same manner as regular matches in tournaments. Overtime periods in consolation matches shall consist of two one-minute periods.

**Control of
Mat Area**

SECTION 6. All personnel other than actual participating contestants shall be restricted to an area reserved for such use. This area shall be well removed from the actual mat area and scoring table.

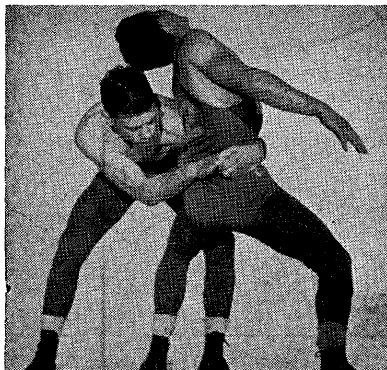

**No. 7—LEGAL USE OF HANDS IN
BODYLOCK**

This complete bodylock is legal because defensive wrestler is in a standing position. This hold would be a technical violation if defensive wrestler had both knees on mat. (See Rule 10, Section 7.)

RULE VIII—DEFINITIONS**Referee's****Position
on the Mat**

SECTION 1. a. Defensive Wrestler. A stationary position in which the defensive wrestler is on his knees facing in the direction indicated by the design with his hands in the center of the mat. He must keep both knees on the mat and they shall not be spread more than the width of the shoulders. The legs must be parallel, with the toes neither turned out or under in an exaggerated position. The heels of both hands must be on the mat not less than 12 inches in front of the knees; and the elbows shall not touch the mat.

b. Offensive Wrestler. The offensive wrestler shall be on his knees at the side of his opponent with his head along the mid line of his opponent's back. The palm of his right (or left) hand shall be placed loosely against the defensive man's navel at the waistline and the palm of his left (or right) hand shall be placed loosely on the back of opponent's near elbow. Both of his knees shall be on the mat outside of defensive wrestler's near leg.

Time**Advantage**

SECTION 2. The offensive wrestler who has control in an advantage position over his opponent is gaining time-advantage. A timekeeper assigned to each wrestler records his accumulated time-advantage throughout the match or a multiple timer may be permitted to record the time-advantage. At the end of the match the Referee subtracts the lesser time advantage from the greater. If the contestant with the greater time-advantage has less than one minute of net time-advantage, no point is awarded. If he has one full minute or more of net time-advantage, he is awarded *one* point by the Referee. No contestant can be awarded more than *one* point for time-advantage in any one match. The contestant with the lesser time-advantage receives no points even though he accumulates several minutes of time in the advantage position.

Note—Control is a situation in which a contestant exercises and maintains restraining power over his opponent.

Position of**Advantage**

SECTION 3. A position in which a contestant is in control of his opponent. Control is the determining factor. The failure of the offensive wrestler to get his head out from the defensive wrestler's arm does not necessarily prevent the offensive wrestler from having control. The offensive wrestler is entitled to this advantage until such time as his opponent gains a neutral position or a reversal. (See Rule 8, Sections 5, 8, 9 and 10.)

Takedown

SECTION 4. Whenever a contestant brings his opponent to the mat and gains control while the supporting points of either wrestler are within the wrestling area he has gained a takedown. Two points are awarded for the first takedown by each wrestler, and one point for each subsequent takedown during the regular match. In overtime matches, two points are awarded for the first takedown by each wrestler and one point for each subsequent takedown.

Note—The supporting points of either wrestler are the parts of the body touching the

mat that bear the weight of the wrestler's body other than the parts with which he is holding his opponent. When down on the mat the usual points of support are the knees, the side of the thigh and the buttocks. In a standing position the feet are the main points of support.

Out-of-Bounds SECTION 5. Contestants are "out-of-bounds" when any supporting part of either wrestler touches or goes beyond the boundary line with the following exceptions:

a. When a take-down is imminent, wrestling shall continue as long as the supporting points of either wrestler remain within the boundary lines of the wrestling area.

b. When a fall is imminent, wrestling shall continue as long as the head and both shoulders of the defensive wrestler are on the mat proper within the boundary lines.

c. When one wrestler has the advantage position the match shall continue as long as the main supporting parts of either wrestler remain within the wrestling area. If however the referee anticipates a difficult situation at the edge of the mat he may in accordance with Rule 13, Section 11, stop the match and resume the wrestling in the center of the mat.

Resumption of Wrestling After Out-of-Bounds SECTION 6. The position to be assumed by the contestants at the resumption of a match shall be neutral or the Referee's position on the mat as determined by the position held upon going out-of-bounds. If neither wrestler has control the match shall be resumed with both wrestlers opposite each other and on the 10-foot circle. If one wrestler has the advantage position he will take the offensive Referee's position in the center of the mat.

Stalemate SECTION 7. When the contestants are interlocked in a position other than a pinning situation in which neither wrestler can improve his position nor tries to improve his position, the Referee shall stop the match and wrestling shall be resumed as for out-of-bounds.

Neutral Position SECTION 8. A position in which neither wrestler has control.

Escape SECTION 9. An escape occurs when the defensive wrestler gains a neutral position while the supporting points of either wrestler are within the wrestling area.

Reversal SECTION 10. A reversal occurs when the defensive wrestler comes from underneath and gains control of his opponent either on the mat or in a rear standing position while the supporting points of either wrestler are within the wrestling area.

Fall SECTION 11. Any part of both shoulders or area of both scapulas held in contact with the mat for one second constitutes a fall. The one-second count (one-thousand-and-one) shall be a silent count by the Referee and shall start only after the Referee is in such position that he knows positively that a fall is imminent, after which the shoulders or scapula area must be held in continuous contact with the mat for one second before a fall shall be awarded.

Note—See High School Section 6, Definitions.

a. A fall shall not be awarded when one or both shoulders or head of the defensive contestant are out-of-bounds. (See Rule 8, Section 5b.)

Note—The head must touch the mat on or outside the boundary line to be considered out-of-bounds.

b. If the defensive wrestler is handicapped by having any portion of his body off the wrestling area, no fall shall be awarded and out-of-bounds shall be declared.

c. When the match is stopped for out-of-bounds in a fall situation, the match shall be resumed in the Referee's position on the mat. (See Rule 8, Sections 1 and 6.)

Near-Fall

SECTION 12. A near-fall is a situation in which the offensive wrestler *has control of his opponent* with both shoulders or the scapula area held in contact with the mat for less than one full second or when one shoulder of the defensive wrestler is touching the mat and the other shoulder is held within one inch or less of the mat for two full seconds. Three points shall be awarded for these situations.

Note—See High School Section 6, Definitions.

Predicament

SECTION 13. A predicament is a situation in which the offensive wrestler *has control of his opponent* and a fall or near-fall is imminent.

a. When both shoulders of the defensive wrestler are held momentarily (stopped) within approximately four inches of the mat or less, a predicament shall be scored. Two points shall be awarded for a predicament. A continuous roll-through is not to be considered a predicament.

b. When one shoulder of the defensive wrestler is touching the mat, and the other shoulder is held at an angle of 45 degrees or less with the mat, but not sufficiently close to award a near-fall, for one second or more, a predicament shall be scored.

Note 1—A near-fall or predicament is ended when the defensive wrestler gets out of the pinning position and into a position in which a fall is no longer imminent.

The Referee must not signal the score for a near-fall or a predicament until the situation is ended. Only one near-fall or one predicament shall be scored in each pinning situation regardless of the number of times the offensive wrestler places the defensive wrestler in a near-fall or predicament position during the situation.

Note 2—Regardless of the length of time a defensive wrestler may be held in a pinning situation, no predicament or near-fall may be awarded except as provided in Rule 8, Sections 12 and 13 above.

Note 3—Only a wrestler with the advantage who has his opponent in a pinning situation may score a near-fall or predicament. Bridgebacks in body scissors or bridgeovers with a wristlock are not considered near-fall or predicament situations although a fall may be scored.

Note 4—When the defensive wrestler places himself in a precarious situation during an attempted escape or reversal, a near-fall or predicament shall not be scored unless the offensive wrestler has control of his opponent in a pinning situation.

Decisions

SECTION 14. If no fall has resulted after expiration of the three regular periods of any match as provided in Rule 7, Section 1, the Referee shall award the match to the contestant who has scored the greater number of points as provided by the point system in Rule 9, Section 2. If there is a tie in the number of points scored, the Referee shall declare the match a draw in dual meets. (See Rule 7, Section 4 for tournaments.)

Forfeit SECTION 15. A forfeit is received by a wrestler when his opponent for any reason fails to appear for the match. In order to receive a forfeit, a wrestler must be dressed and appear on the mat. (See Rule 5, Section 3.)

Default SECTION 16. A default is awarded in a match when one of the wrestlers is unable to continue wrestling due to an injury.

RULE IX—SCORING

Team Score SECTION 1. *a. Dual Meet.*

(1) *Fall.* Five points shall be scored toward the team total for each contestant who wins by a fall, default or forfeit.

(2) *Decision.* The decision shall count three points on the team score.

(3) *Draw.* In case of a tie two points shall be scored for each team.

b. Tournaments. In tournaments, first place in each weight class shall count 10 points, second place 7 points, third place 4 points and fourth place 2 points. These points shall be awarded as soon as earned. At the conclusion of the championship semifinals, each winner shall receive seven points. At the conclusion of the championship finals, each winner shall receive three additional points, each loser no additional points. At the conclusion of the

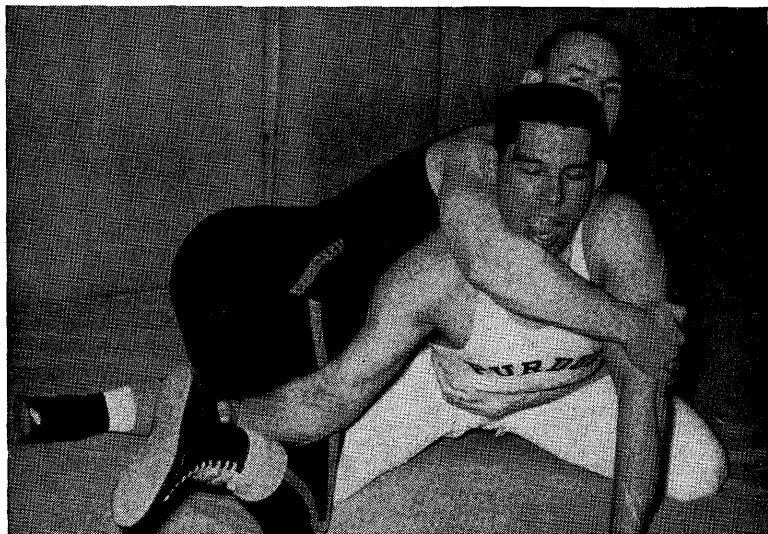

No. 8—ILLEGAL TWISTING KNEE LOCK

This shows the start of a twisting knee lock. If the leg is forced further this will become an illegal hold (Rule 10, Section 1). The Referee should anticipate the danger of injury from this hold and be in a position to block it before it reaches the danger point.

consolation semifinals, each winner shall receive two points. At the conclusion of the final third place matches, each winner shall receive two additional points, each loser no additional points. One additional point shall be scored for each match won by a fall, default or forfeit throughout the tournament. In addition, one point shall be scored for each match won in both the championship and consolation eliminations except for the final first and third place matches. No points are awarded for a bye in any round.

c. *National Collegiate Championships.* In the National Collegiate Championship six places shall be awarded. The defeated wrestlers in the consolation semi-finals shall wrestle off for the fifth and sixth places. The scoring shall be as follows: first place 10 points, second place 7 points, third place 5 points, fourth place 3 points, fifth place 2 points and sixth place 1 point.

**Match Point
Score System**

SECTION 2. In all matches the contestants are awarded points by the Referee in accordance with the following system:

First Takedown (by each wrestler) (Rule 8, Sec. 4)	2 points
Subsequent Takedown (Rule 8, Sec. 4)	1 point
Escape (Rule 8, Sec. 9)	1 point
Reversal (Rule 8, Sec. 10)	2 points
Near-Fall (Rule 8, Sec. 12)	3 points
Predicament (Rule 8, Sec. 13)	2 points
Time Advantage (Rule 8, Sec. 2)	1 point for one full minute or more of net accumulated time in the advantage position. <i>One point is the maximum to be awarded for the match and this point shall be recorded on the final score.</i>

Penalties (See Rule 11 and the Penalty Chart)

Note—Method of Recording Score for an Overtime Match.

Example: 3-3, 1-0 (OT)*

3-3, 1-1, (UD,SD)**

* OT — Overtime

**UD — Unanimous Decision

SD — Split Decision

SUMMARY OF SCORING

<i>Individual Match Points</i>	<i>Tournament Points</i>
First Takedown (by each wrestler) 2 pts.	1st Place 10 pts.
Subsequent Takedown 1 pt.	2nd Place 7 pts.
Escape 1 pt.	3rd Place 4 pts.
Reversal 2 pts.	4th Place 2 pts.
Near Fall 3 pts.	Fall 1 pt.
Predicament 2 pts.	Default 1 pt.
Time Advantage 1 pt.	Forfeit 1 pt.
(maximum for one or more minutes)	* Advancement (Rule 9, Sec. 1b) 1 pt.
	<i>Dual Meet Points</i>
Fall 5 pts.	Decision 3 pts.
Forfeit 5 pts.	Draw 2 pts.
Default 5 pts.	

RULE X—INFRACTIONS

Illegal Holds SECTION 1. Any hold shall be allowed except the hammer lock above the right angle; the twisting hammer lock; front headlock; the straight head scissors (even though the arm is included); over-scissors; flying mare with the palm up; full (double) nelson; strangle holds; all body slams; toe holds; twisting knee lock; the bending, twisting or forcing of the head or any limb beyond its normal limits of movement; locking the hands in a double arm bar from a neutral position; and any hold used for punishment alone.

Note 1—Contestants may grasp all four fingers in an effort to break a hold, but pulling back the thumb, or one, two or three fingers is illegal.

Note 2—The term "slam" is interpreted as lifting and bringing an opponent to the mat with *unnecessary roughness*. This infraction may be committed by a contestant in either the top or bottom position on the mat as well as on a takedown. A contestant who lifts his opponent clear of the mat is responsible for the safe return of that opponent to the mat. A forceful trip is not interpreted as an illegal slam providing the defensive wrestler is not lifted completely off the mat.

Note 3—A leg hooked over the top toe of an opponent's straight body scissors is interpreted as an over-scissor and therefore illegal.

Note 4—A wrestler applying a legal hold should not be penalized when his opponent turns the legal hold into an illegal hold. The Referee shall cause the hold to be released if there is danger of injury. However, the match need not be stopped unless the Referee finds it necessary to do so in order to correct the situation.

Note 5—Whenever possible an illegal hold should be prevented rather than called.

Unnecessary Roughness SECTION 2. Intentional striking, gouging, kicking, hair pulling, butting, elbowing or any intentional act that endangers life or limb shall be grounds for disqualification on first penalty if the referee considers such act as flagrant misconduct. The referee shall follow the penalty chart for the penalties in the case of less flagrant unnecessary roughness. (See Penalty Chart.)

Foreign Substance on Skin SECTION 3. The use of oil or greasy substances which cannot be completely removed shall be grounds for disqualification at the discretion of the Referee. Time out for the removal of such foreign substance shall be cumulative with the time out for injuries throughout the match. The total time out shall not exceed three minutes (See Rule 12, Section 1.)

Objectionable Pads and Braces SECTION 4. (See Rule 3, Section 4 and the Penalty Chart.)

Abusive Conduct SECTION 5. Conduct of a coach, contestant, or spectator that becomes abusive or interferes with the orderly progress of a match shall be grounds for removal from the premises. The home management shall be responsible for the removal of the violators at the request of the Referee. (See Penalty Chart.)

Potentially Dangerous Holds SECTION 6. The double wristlock, chicken wing, key lock, overhead double arm bar, split scissors, and other holds may cause injury when used legally, and are potentially dangerous holds. Contestants should know the dangers of these holds and the blocks for them. The Referee should anticipate danger of injury from these holds and be in position to block them before they reach the danger point. Furthermore, all Referees, coaches and contestants should understand that any and all holds used in such a way as to endanger life or limb are illegal and all

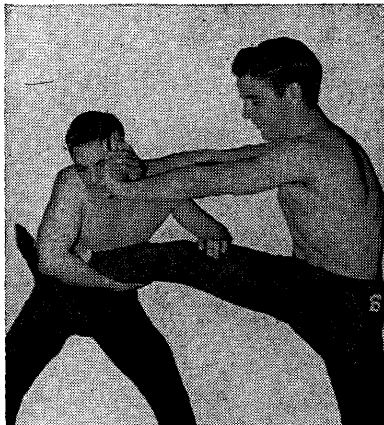

No. 9—LEGAL BLOCKING ON
FACE (ON CHIN)

Blocking on chin or forehead is legal but is not legal over face proper; that is, over mouth, nose or eyes.

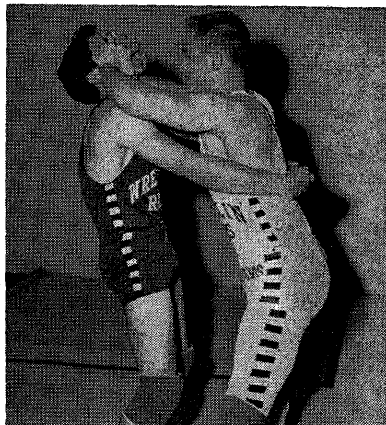

No. 10—ILLEGAL BLOCKING ON
FACE (ON FACE PROPER)

This form of blocking is illegal because it is over mouth, nose and eyes, in contrast to position in No. 9.

Referees should verbally caution contestants against forcing a potentially dangerous hold into an illegal position. The double wristlock and chicken wing become illegal when forced into a twisting hammer lock position as in the case of applying the force parallel instead of perpendicular to the long axis of the body.

It should be understood that no contestant should ever be put in a position where he must forfeit a neutral position, a position of advantage or a fall because of an injury or danger to life or limb, and the Referee should promptly stop any and all holds which in his opinion may so result. If a legitimate hold is forced to such an extent as to endanger a contestant or if it becomes a punishing hold, the Referee shall stop the match and require the hold to be broken. The match shall be resumed in the neutral or Referee's position as determined by the position held at the time the match was stopped.

a. Any holds over the mouth, nose, eye or front of throat shall not be permitted. Pressure from the side of the hand, forearm or wrist is considered a hold and therefore barred when used on the mouth, nose, eyes or front of throat. Forcing such a hold may be considered unnecessary roughness depending on the intent of the act as determined by the Referee and shall be penalized accordingly.

Technical Violations

SECTION 7. a. *Interlocking Hands.* Interlocking of fingers hands or arms, around the body or both legs by the offensive contestant while on the mat is a technical violation. This has reference only to the wrestler in the position of advantage on the mat and does not apply when the defensive man has gained his feet or



No. 11—ILLEGAL FACE HOLD

Shows a hold commonly used but which is contrary to both the letter and spirit of amateur wrestling rules. It is frequently used momentarily in order to prevent defensive wrestler from coming out from underneath or to bring defensive wrestler back into position for a fall. Referee should see that offensive wrestler does not secure unfair advantage by means of this illegal action.

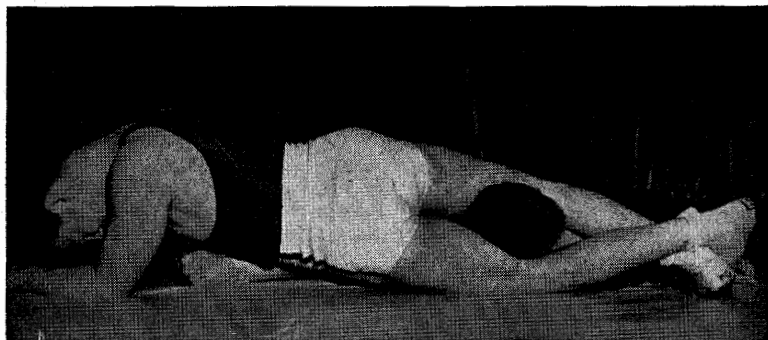

No. 12—ILLEGAL HEAD-SCISSORS

This hold is illegal. All straight scissors on the head are illegal.

when the lock is used as a pin hold. Interlocking of fingers, hand or arms, is permitted when the defensive man is standing. The mere touching of the defensive man's hands to the mat is not considered a change in this position unless the hands are used as supporting parts, in which case, the offensive contestant is allowed reaction time to release the lock. It is unsportsmanlike for the defensive contestant to touch his hands to the mat in order to release the offensive wrestler's lock and the Referee shall not call a violation if the lock is held in such cases.

Note—The Referee shall not call this violation when the defensive man is in the process of a reversal or escape. The defensive man is allowed to complete the reversal or escape provided he does so in a continuous maneuver. If the defensive man fails to complete the reversal or escape after an opportunity to do so, the Referee will stop the match and award the penalty. (See Penalty Chart.)

b. Leaving Mat Without Permission. It is a technical violation to leave the mat without first receiving permission to do so from the Referee.

c. Delaying Match. Delaying the match such as straggling back from out-of-bounds, unnecessary changing and adjusting equipment, repeatedly assuming incorrect referee's position and repeatedly making false starts from the referee's position are technical violations.

d. Intentional Forcing Opponent Off Mat. Intentional forcing opponent off the mat to prevent a take-down, reversal or an escape is a technical violation. (See Penalty Chart.)

e. Intentional Going Off Mat. Intentionally going off the mat to prevent a take-down, reversal or escape is a technical violation. (See Penalty Chart.)

f. Defensive Wrestler Intentionally Going Off Mat. Is a technical violation if the defensive wrestler intentionally walks, crawls, rolls or bridges off the mat. No penalty is provided if a near-fall or predicament is awarded during this violation.

Note—See Penalty Chart Note***.

Note—It is considered a violation if the contestant in a figure-four body scissors intentionally goes off the mat to get the hold released.

g. Stalling. It is the responsibility of both contestants to maintain action throughout the match by making an honest attempt to stay in the circle and wrestle aggressively whether in the top, bottom or neutral positions. (See Penalty Chart.)

(1) *Neutral Position.* Each wrestler must make an honest attempt to stay in the circle and secure a take-down regardless of the time or score of the match. A contestant who continually avoids contact with his opponent is stalling. A contestant may leave the circle to maneuver for position provided he continues his attempt to gain an advantage and makes an effort to work back into the circle. Taking a position near the edge of the mat for the purpose of going off the mat, or allowing his opponent to push him off when the opponent makes an effort to go behind, is stalling.

(2) *Advantage Position.* The contestant in the advantage position on the mat shall make an honest attempt to wrestle aggressively. A period of twenty seconds shall be sufficient time for the Referee to decide whether or not a contestant retaining a stalling hold has made an attempt to improve his position. For the second and subsequent penalties a period of fifteen seconds shall be sufficient time to determine the intent to stall.

Note—Any legal hold is not to be construed as a stalling hold if in the opinion of the Referee the offensive wrestler has a fair chance to pin his opponent and is making a real effort to do so.

(3) *Defensive Position.* Refusing to wrestle aggressively in the defensive



No. 13—LEGAL HEAD-SCISSORS (FIGURE 4 HEAD-SCISSORS)

The straight head-scissor is illegal. The figure 4 Head-Scissor is considered legal when taken as shown above, with the hold on either side of the face.

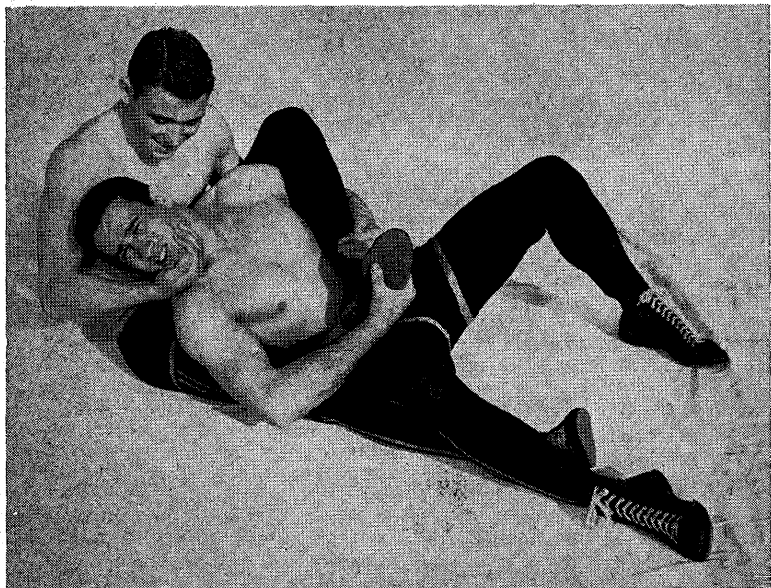

No. 14—LEGAL FOOT (INSTEP) HOLD

The defensive wrestler may grasp the instep, heel or ankle in his effort to escape, providing the pressure is not such as to endanger the ankle, knee or hip joint.

position is stalling and shall be penalized as a technical violation. (See Penalty Chart.)

Note—When there is no action in the mat position, the responsibility for initiating the action rests with the defensive wrestler.

(4) *Holding Legs*. It is considered stalling for the wrestler in the advantage position on the mat to grasp the defensive wrestler's leg or legs with both hands or arms unless such action is designed to break his adversary down and go into a pinning combination or to prevent an escape or reversal. Repeatedly grasping and holding the leg or legs with both hands or arms merely to break the defensive wrestler down or to keep him under control for the purpose of stalling is a violation under this rule. This has reference only to the wrestler in the position of advantage on the mat, and does not apply when the defensive man has gained his feet.

h. Grasping Clothing, etc.: No grasping of clothing, mat or mat cover by a contestant is permitted and any advantage gained thereby shall be nullified. Grasping clothing to prevent or gain an escape, reversal, takedown, or fall, is a technical violation.

Note—(Treat same as Note under Rule 10, Section 7a.)

RULE XI—PENALTIES

SECTION 1. The infractions of the rules are penalized in accordance with the penalties as listed on the Penalty Chart. (Page 84)

SECTION 2. In calling each penalty the Referee shall stop the match, give the hand signal for the points or warning (pages 99 and 100) and announce the penalty so that the contestants, scorers, coaches and spectators are aware of it.

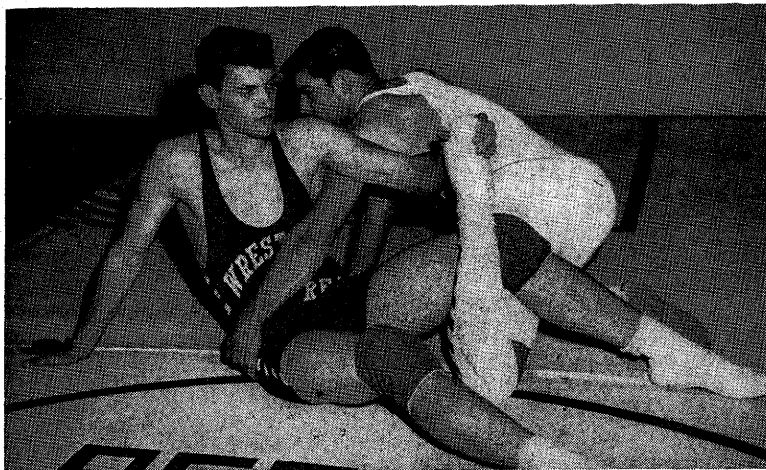

No. 15—ILLEGAL TOEHOOLD (ALSO TWISTING KNEELOCK WHICH IS MORE DANGEROUS THAN TOEHOOLDS)

All toeholds, regardless of the degree to which the leg is twisted are illegal under these rules. Any pressure against the knee joint as shown by the above illustration constitutes an illegal hold.

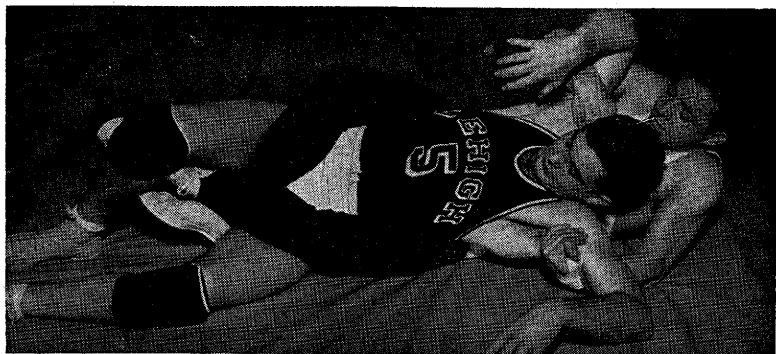

No. 16—OVER-SCISSORS (AN ILLEGAL HOLD)

The over-scissors is barred entirely under these rules because it is only a punishing hold and is of no value unless defensive contestant who uses it is allowed to force the hold, which thereby endangers the ankle and knee of his opponent.



No. 17—FULL NELSON—AN ILLEGAL HOLD

Most of the difficulty has arisen when the three-quarter is confused with the full nelson. In the full nelson the aggressor places both arms under his opponent's arms and clasps his hands or wrists on the back of his opponent's head (See Figure No. 24)

Sequence of Penalties including overtime.

SECTION 3. The penalty chart indicates the sequence of penalties and they are cumulative throughout the match

RULE XII—INJURIES AND DEFAULTS

SECTION 1. An injured contestant has a maximum time-out of three minutes which is cumulative throughout the match including the overtime. Nose bleed or any other excessive bleeding shall not be interpreted as an injury and the number and length of time-out periods for such bleeding is left to the discretion of the Referee. There shall be no limit to the number of time-out periods which may be taken in any match, but the total time-out shall not exceed three minutes. If, at the expiration of the time-out, he is able to continue wrestling, the match shall be resumed as if the contestants had gone out-of-bounds.

If a contestant is rendered unconscious he shall not be permitted to continue the match without the approval of a physician. If the injured contestant is unable to continue wrestling, the match shall be awarded in accordance with Sections 2 and 3 of this rule.

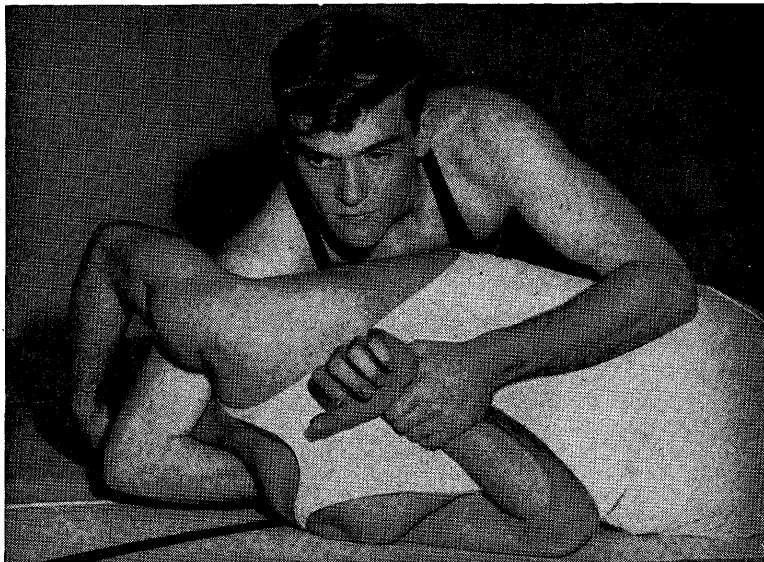

No. 18—ILLEGAL HAMMERLOCK (ABOVE RIGHT ANGLE)

The hammerlock is a legal hold, provided the arm is not bent above the right angle (i.e., provided that the arm is not carried above the small of the back); and provided, further, that the hand is not forced out away from the body, making it a twisting hammerlock. In this illustration the arm is carried distinctly above the right angle and is dangerous.

PENALTY CHART

Infractions	First Penalty	Second Penalty	Third Penalty	Fourth Penalty	Rule 10 Sections
Illegal Holds *Technical Violations ***Unnecessary Roughness	1 pt. N.C.	1 pt. N.C.	2 pts. N.C.	**Disqualify	1 7 2
Abusive and/or Unsportsmanlike Conduct (See Rule 13, Sec. 16)	Warning	Deduct 1 team point	Remove from Premises		5
Flagrant Misconduct	Disqualify on first penalty				2
Greasy Substance on Skin and/or Objectionable Pads and Braces	Disqualify if cannot be removed in allotted time				3 4

Key: N.C.—no change

SUMMARY OF TECHNICAL VIOLATIONS (Rule 10, Sec. 7):

- Interlocking Hands (Sec. 7, a)
- Holding Legs (Sec. 7, g (4))
- Leaving Mat Without Permission (Sec. 7, b)
- Delaying Match (Sec. 7, c)
- Intentional Forcing Opponent Off Mat (Sec. 7, d)
- Intentional Going Off Mat (Sec. 7, e, f)
- Stalling (Sec. 7, g, (1), (2), (3), (4))
- Grasping Clothing, etc. (Sec. 7, h)

*Note. On technical violations involving stalling a verbal warning shall be given before the first penalty is assessed.

**Note. Disqualification due to a technical violation, illegal holds, or less flagrant unnecessary roughness does not eliminate a contestant from competition for third place in tournaments. Disqualification for any other reason eliminates a contestant from competition for third place in tournaments.

***Note. Points for unnecessary roughness may be awarded in addition to points earned.

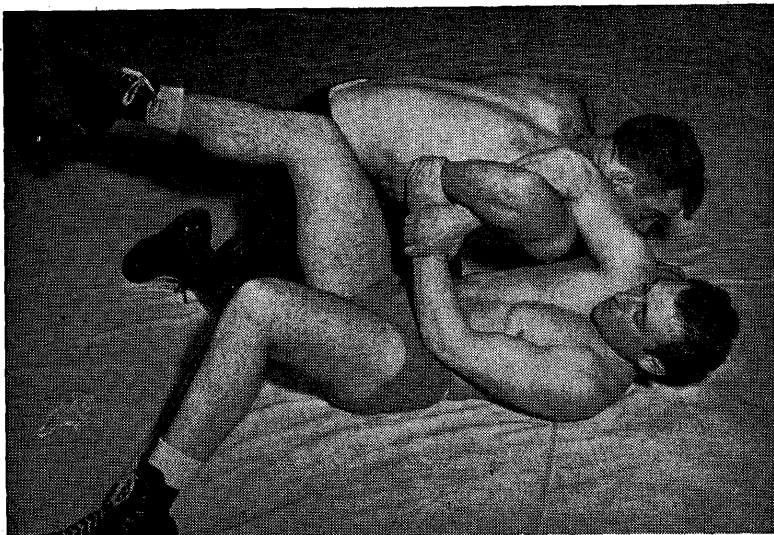

No. 19—LEGAL DOUBLE WRISTLOCK ON THE MAT

The double wristlock on the mat is legal if the direction of the force is perpendicular to the long axis of the body.

Accidental Injury

SECTION 2. If a contestant is accidentally injured and is unable to continue the match, his opponent shall be awarded the match by default due to injury.

Inquiry from illegal Action

SECTION 3. If a contestant is so injured by any illegal action that he is unable to continue, the match shall be defaulted to the injured contestant and shall be scored as a fall. In case of an intentional attempt to injure an opponent, the offender shall be disqualified. (See Rule 10, Section 2 and Penalty Chart for "Flagrant Misconduct.")

Attendants During illegal Action

SECTION 4. No more than two attendants and a physician shall be permitted on the mat with a wrestler during time-out.

RULE XIII—OFFICIALS

Referee's Duties

SECTION 1. On matters of judgment the Referee shall have full control of the meet and his decisions shall be final and without appeal. On matters of a technical nature, the current NCAA Rules shall be the final authority.

SECTION 2. Before the contestants come to the mat the Referee shall:

a. Inspect contestants for presence of oils or greasy substances, rosin, objectionable pads, improper clothing, finger rings, long finger nails, etc.

b. Clarify the rules with coaches and contestants.

c. Advise contestants to report on the circle at the center of the mat opposite each other ready to wrestle.

SECTION 3. The referee is responsible for the seating arrangement at the officials table in accordance with one of the diagrams below:

WHEN INDIVIDUAL CLOCKS OR STOP WATCHES ARE USED

Home Team Assistant Timekeeper	Visiting Team Assistant Timekeeper	Match Timekeeper	Visiting Team Scorer	Home Team Scorer
--------------------------------------	--	---------------------	-------------------------	---------------------

WHEN MULTIPLE TIMER IS USED

Timekeeper	Visiting Scorer	Announcer or Home Scorer
------------	-----------------	--------------------------

SECTION 4. Instruct the Match Timekeeper that he is:

a. In charge of assistant timekeepers, and scorers, and should be constantly checking their activities at all times.

b. Responsible for keeping the over-all time of the match.

c. Responsible for recording accumulated time-outs for injury.

d. Responsible for informing the Referee, only after an imminent situation has passed, whenever there is disagreement by the official scorers and/or timekeepers.



No. 20—ILLEGAL DOUBLE WRISTLOCK ON THE MAT

This cut shows double wristlock turned into a typical twisting hammerlock that will injure opponent's shoulder if the arms are forced upward, unless opponent turns with the pressure, which often he is unable to do promptly enough to prevent injury to the shoulder.

e. Responsible for assisting the Referee in determining whether a situation occurred before or after the termination of a period.

f. Responsible for calling the minutes to the Referee, contestants, and spectators in each match. The last minute shall be reported at fifteen second intervals. (45, 30, 15 seconds.)

Note—The Home Institution shall provide each timekeeper with an accumulative time clock for recording the time during the match. The match timekeeper shall be provided with two extra accumulative time clocks for recording time out in case of injury to the contestants. The match timekeeper shall also be provided with a gong, horn, or bell.

A multiple timer may be used in place of time clocks.

SECTION 5. Instruct the Assistant Timekeepers that they are responsible for:

a. Recording the accumulative time advantage of the contestants, to whom they have been assigned when indicated by the Referee.

b. Constantly checking each other's time advantage recording.

c. Constantly checking the match timekeeper's time recording.

d. Showing the Referee the stop clock recording of the time advantage each contestant has accumulated at the end of the match.

e. Stopping time advantage when the Referee signals illegal interlocking of hands.

SECTION 6. Instruct the Scorers that they are responsible for:

a. Recording which contestant has the position of advantage at the start of the second and third periods.

b. Recording points scored by both contestants when signaled by the referee.

c. Constantly checking each other's score reading.

d. Immediately advising the match timekeeper when they are in disagreement regarding the score.

e. Keeping the score board operator continually advised of the official score during each match.

f. Showing the Referee the scorecard at the end of each match.

SECTION 7. Before the dual meet starts call the team captains to the center of the mat for the toss of the coin to determine the choice of position at the start of the second period. (Rule 7, Section 3.)

SECTION 8. The Referee will use the Wrestling Officials Signals.

SECTION 9. The Referee shall notify the timekeepers as follows:

a. When the match is started or stopped for any reason.

b. When time advantage begins or ends for a contestant.

c. Whenever time is involved in any situation occurring in the match.

SECTION 10. The Referee shall notify the scorer, when warnings or points are awarded to either contestant. (See Signals for Referees.)

SECTION 11. The Referee should anticipate difficult positions on the edge of the mat and prevent them by stopping the match, and resume wrestling at the center of the mat, as in the case of an off-mat decision.

SECTION 12. The Referee shall be firm in enforcing the letter and spirit of the rules and penalize consistently any repeated infractions. He must



No. 21—ILLEGAL FRONT HEAD LOCK

This cut shows how the front head lock is used to counter a leg pickup. This hold is dangerous and is illegal.

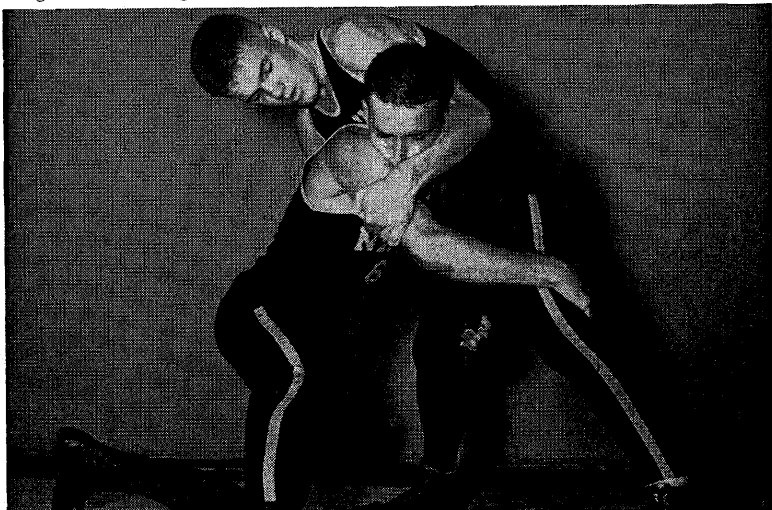

No. 22—A LEGAL CROSS FACE

It is an effective and legal block for the double leg pick-up.

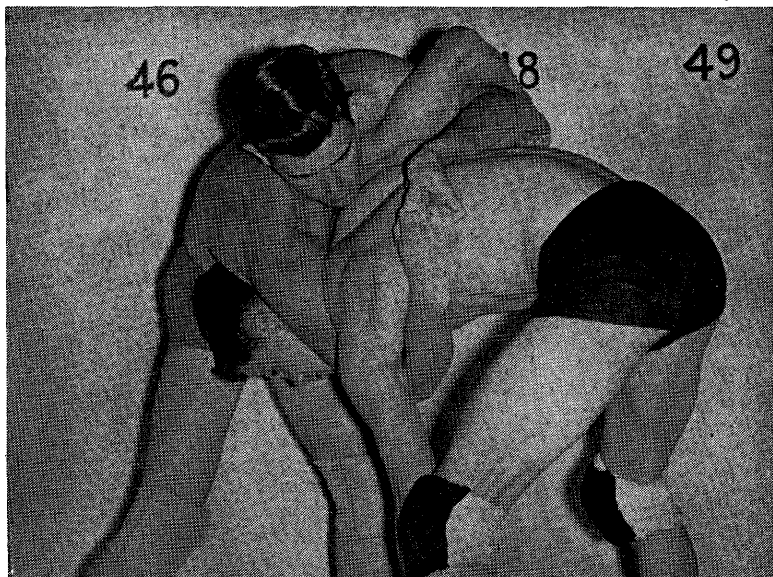

No. 23—ILLEGAL DOUBLE ARM BAR

Locking hands in a double arm bar from a neutral position.

enforce vigorously and promptly the penalties for the infractions as provided in Rules 10 and 11. On each penalty the referee shall stop the match and announce the penalty in the prescribed manner so that the contestants, scorers, coaches and spectators are aware of it. (See Signals for Referees.)

SECTION 13. The Referee shall caution the user of a potentially dangerous or illegal hold in order to prevent possible injury. Such holds should be stopped by the Referee, if possible, before reaching the dangerous stage.

SECTION 14. The Referee should not place his hands under the shoulders of a contestant unless absolutely necessary to determine a fall.

SECTION 15. The Referee should meet promptly, in a spirit of good sportsmanship, any situation developing unexpectedly.

SECTION 16. If the conduct of a coach, contestant, or a spectator interferes with the orderly progress of the match, the home management shall be responsible, at the request of the Referee, for the removal of the offender from the premises. (See Penalty Chart.)

SECTION 17. At the end of a match the referee shall order the contestants to shake hands and raise the hand of the winner. If there is a doubt as to the winner the Referee shall order the contestants to stay on the mat while he checks the time advantage and the scorer's records to decide the

winner. The time advantage, if any, shall be recorded on the score board and the referee shall declare the winner in accordance with the instructions in the first sentence of this section. In dual meets, if the match is a draw the referee will raise one hand of each wrestler.

Note 1—If in the opinion of the Referee there is an error in the recordings of the timekeepers and/or scorers, the Referee shall correct the error and render his decision accordingly.

Note 2—In overtime periods if the points are even the referee and two judges shall determine the winner by ballot. (See Rule 7, Section 4.)

RULE XIV—NOTIFICATION AND AGREEMENT OF MEETS

Equal Rights for Visiting Teams

SECTION 1. All modifications of rules of competition, "ground rules," etc., proposed by the home manager, must be submitted to the manager of the visiting team, or teams, a sufficient length of time before date of meet for agreement to be reached on same, and no such action is binding unless approved by the visiting team or teams.

SECTION 2. In dual meets the selection of a Referee and the maximum weigh-in time shall be mutually agreed upon at least ten days prior to date of meet.

Note—In case the Coaches concerned are unable to agree on a shorter maximum weighing-in time than the five hours specified as the maximum in these rules, it is understood that the maximum amount of time as specified in the rules shall hold.

SECTION 3. The home management shall notify visiting teams at least ten days prior to date of meet the exact time and place of the meet, the name of the referee, and if shirts will be required.

HIGH SCHOOL MEMBERS OF RULES COMMITTEE

The National Federation of State High School Athletic Associations' two representatives on the NCAA Wrestling Rules Committee are appointed by the National Federation's Executive Committee annually. That is, the appointees serve for one year periods. They are eligible to succeed themselves.

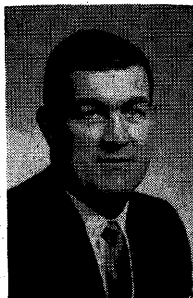

John E. Roberts

The National Federation appoints its Rules Committee Members from among those men who are particularly qualified and interested in interscholastic wrestling. It is desired to secure persons who have actively participated in the sport as contestants and officials. We attempt to secure representatives who are dedicated to the activity, so that they will make significant contributions to the Committee's work and, so that they will take part in interpretation meetings and research.

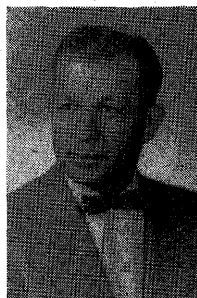

Finn B. Eriksen

Supplementary Modifications for Interscholastic Wrestling

The NCAA Rules shall apply with the following exceptions:

1. Eligibility. Contestants shall be eligible under the rules of the High School Athletic Association of the State in which their school is located.

2. Weight Classification. Competition shall be divided into weight classes as follows:

103 lbs.	127 lbs.	145 lbs.	165 lbs.
112 lbs.	133 lbs.	154 lbs.	Unlimited
120 lbs.	138 lbs.		

The 95 and/or 180-lb. classes may be officially included in the weight classification provided either or both are adopted by individual state association. Interstate dual meets shall be conducted in the original ten weights.

Beginning January 1st and continuing until February 1st, two additional pounds will be allowed in each weight class. Beginning February 1st and continuing for the remainder of the season, one additional pound shall be allowed in each weight class. This will make a net increase of three pounds beginning the 1st of February.

Weight Control Recommendation. The Rules Committee recommends that Individual State Associations formulate a weight control program.

3. Costume. Shirts are mandatory.

4. Weighing In of Contestants.

A. DUAL MEETS. Contestants may weigh in a maximum of one hour and a minimum of one-half-hour before time the meet is scheduled to begin. (By mutual consent of the competing schools the college regulations may be followed.)

B. TOURNAMENTS. Each day of the tournament, contestants may weigh in a maximum of five hours and a minimum of one hour before the meet is to begin, with one pound allowance to be given each day over the weight limit of the previous day.

Note. Changes in weighing in time may be made by the individual state associations.

5. Length of Matches.

A. DUAL MEETS. These matches shall be six minutes in length divided into three periods of two minutes. No rest is allowed. These matches shall be conducted in the same manner as set forth in Rule 7 and Rule 8, Section 14.

B. TOURNAMENT. These matches shall consist of three periods of two minutes each, conducted in the same manner as third-place matches under Rule 7, Sec. 5. If a match results in a tie, it shall be decided in accordance with Rule 7, Sec. 4, except the overtime shall consist of *two one-minute periods*.

6. Definitions:

A. **FALL.** Any part of both shoulders or area of both scapulas held in contact with the mat for two seconds constitutes a fall. The two-second count (one-thousand-and-one, one-thousand-and-two) shall be a silent count by the Referee and shall start only after the Referee is in such position that he knows positively that a fall is imminent, after which the shoulders or scapula area must be held in continuous contact with the mat for two seconds before a fall shall be awarded.

(1) A fall shall not be awarded when one or both shoulders or head of the defensive contestant are out-of-bounds. (See Rule 8, Section 5b.)

Note—The head must touch the mat on or outside the boundary line to be considered out-of-bounds.

(2) If the defensive wrestler is handicapped by having any portion of his body off the wrestling area, no fall shall be awarded and out-of-bounds shall be declared.

(3) When the match is stopped for out-of-bounds in a fall situation, the match shall be resumed in the Referee's position on the mat. (See Rule 8, Section 1 and 6.)

B. **NEAR-FALL.** A near-fall is a situation in which the offensive wrestler has control of his opponent with both shoulders or the scapula area held in contact with the mat for one full second or when one shoulder of the defensive wrestler is touching the mat and the other shoulder is held within one inch or less of the mat for two full seconds. Three points shall be awarded for these situations.

C. **PREDICAMENT.** A predicament is a situation in which the offensive wrestler has control of his opponent and a fall or near-fall is imminent.

(1) When both shoulders of the defensive wrestler are held momentarily (stopped) within approximately four inches of the mat or less, a predicament shall be scored. Two points shall be awarded for a predicament. A continuous roll-through is not to be considered a predicament.

(2) When one shoulder of the defensive wrestler is touching the mat, and the other shoulder is held at an angle of 45 degrees or less with the mat, but not sufficiently close to award a near-fall, for one second or more, a predicament shall be scored.

Note 1—A near-fall or predicament is ended when the defensive wrestler gets out of the pinning position and into a position in which a fall is no longer imminent.

The Referee must not signal the score for a near-fall or a predicament until the situation is ended. Only one near-fall or one predicament shall be scored in each pinning situation regardless of the number of times the offensive wrestler places the defensive wrestler in a near-fall or predicament position during the situation.

Note 2—Regardless of the length of time a defensive wrestler may be held in a pinning situation, no predicament or near-fall may be awarded except as provided in the definitions above.

Note 3—Only a wrestler with the advantage who has his opponent in a pinning situation may score a near-fall or predicament. Bridgebacks in body scissors or bridgeovers with a wristlock are not considered near-fall or predicament situations although a fall may be scored.

Note 4—When the defensive wrestler places himself in a precarious situation during an attempted escape or reversal, a near-fall or predicament shall not be scored unless the offensive wrestler has control of his opponent in a pinning situation.

7. **Illegal Holds.** In addition to the illegal holds barred in Rule 10, all headlocks without the arm or leg included, and the overhead double arm bar are illegal.

Note 1—The full three-quarter nelson is not to be interpreted as a headlock.

Note 2—Pulling the head over the shoulder with hands locked or overlapped is not to be interpreted as a headlock.

A. LEGAL HEAD HOLDS.

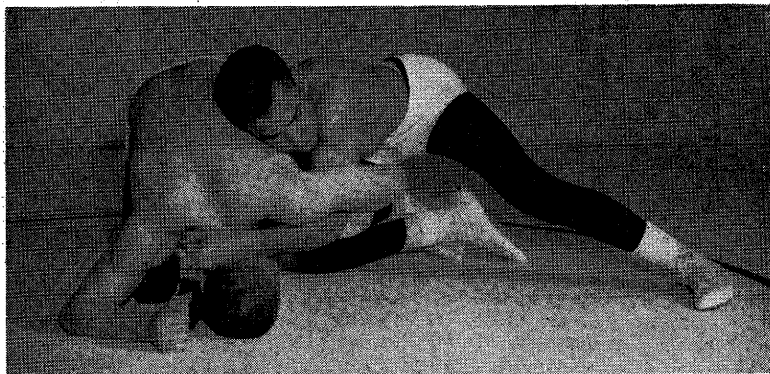

No. 24—FULL $\frac{3}{4}$ NELSON; A LEGAL HOLD

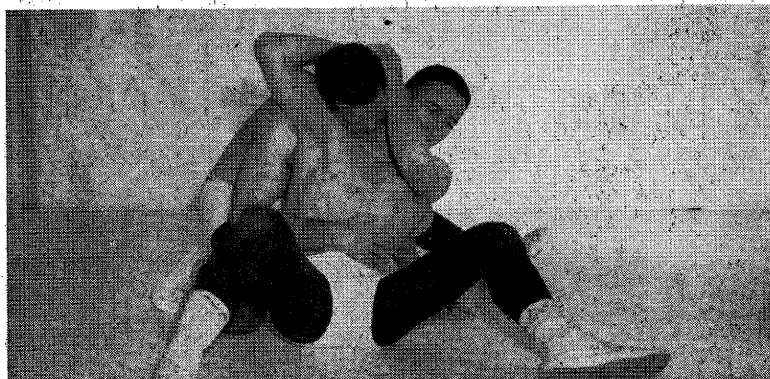

No. 25—A LEGAL HOLD

Pulling the head over the shoulder with hands locked or overlapped.

B. ILLEGAL HEADLOCK. An illegal headlock shall be interpreted as locking or overlapping the hands or arms around an opponent's head or neck without including the opponent's arm or leg in the hold.



No. 26—ILLEGAL HEAD LOCK
Locking the arm around the head.



No. 27—LEGAL HEAD LOCK
Opponent's arm is included in the lock.

C. ILLEGAL GUILLOTINE. If the wrestler locks or overlaps his hands or arms around his opponent's head or neck in securing this hold and the opponent's arm is not included, this is an illegal hold.



No. 28—ILLEGAL GUILLOTINE
Arm is locked around opponent's head or neck.

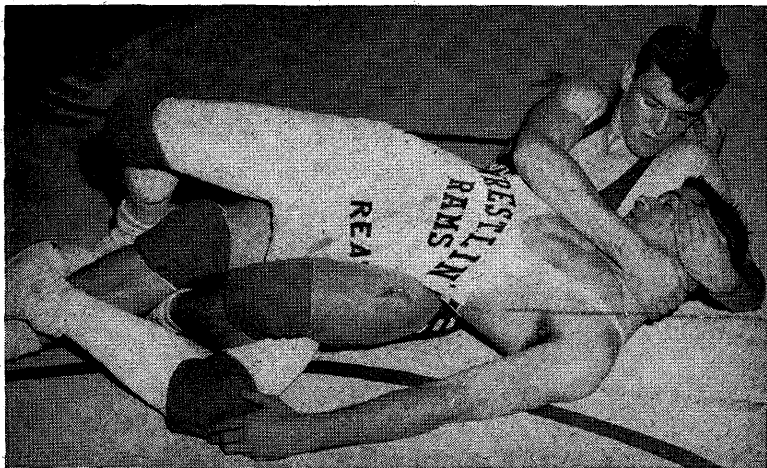

No. 29—LEGAL GUILLOTINE

Hands are not locked or overlapped around head or neck.

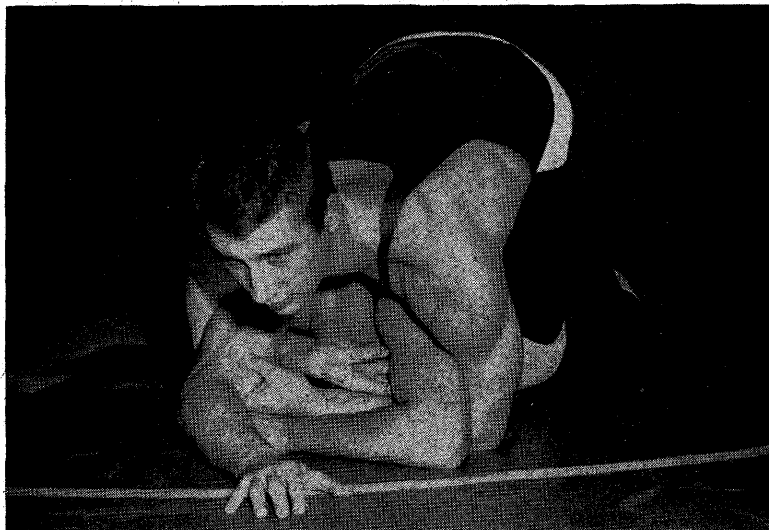

No. 30—ILLEGAL OVERHEAD DOUBLE ARM BAR

This hold is illegal when used as shown above either with or without the scissor.

Referees' Signals

The signals illustrated on the following pages are standard for wrestling referees throughout the nation. It is the duty of every referee to know these signals in order to give them instantly and clearly so that the wrestlers, timers, scorers and spectators are aware of what is taking place during the progress of the match.

SECTION 1. Referee's attire for all dual meets and tournaments:

- a. White dress shirt.
- b. White full length trousers.
- c. White Sox and gym shoes.
- d. Black belt.

Other accessories — silver dollar or disk and whistle.

The Use of the Whistle

SECTION 2. The whistle should be held ready for immediate use at all times during the match.

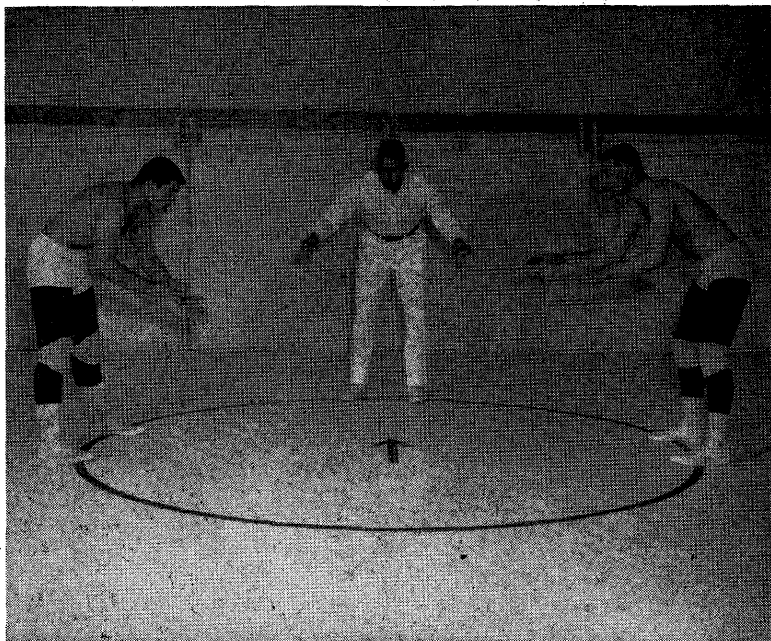

Fig. 1. DESIGNATING THE POSITIONS OF THE WRESTLERS BEFORE THE START OF THE MATCH. As the wrestlers come onto the mat the Referee points to the places they are to take on the circle. He next points one hand toward the timers and scorers to verify their readiness.

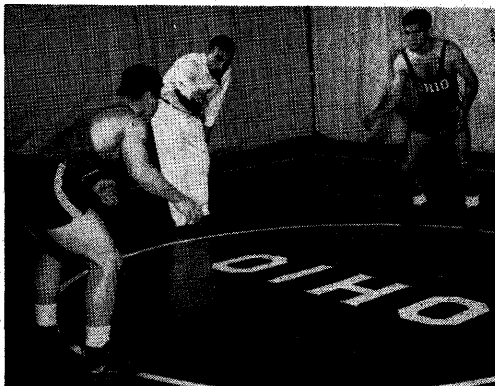

Fig. 2. (top left) SHAKING HANDS AND PASSING BY. After the officials indicate they are ready at the table, the Referee directs the wrestlers to shake hands, pass by and be ready to wrestle when the whistle blows. The Referee motions for the wrestlers to shake hands and pass by crossing his arms in front of his body.

Fig. 3. (top right) STARTING THE MATCH OR RESUMING THE MATCH IN A NEUTRAL POSITION. After the wrestlers pass by they turn and face each other. The Referee raises his hand forward between two wrestlers. After a momentary pause to make certain the wrestlers are ready he blows his whistle and simultaneously moves his hand as a signal for the wrestlers to go into action.

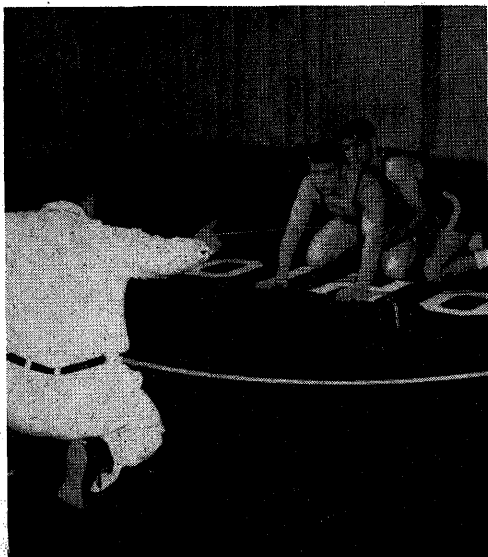

Fig. 4. (bottom left) RESUMING THE MATCH IN THE REFEREE'S POSITION ON THE MAT. The Referee should face the officials table and kneel on one knee at a distance of 8 to 10 ft. in front of the wrestlers and a little to the side on which the top wrestler stations himself. The Referee may give a preparatory command such as "get set" or "ready." When the wrestlers are in proper positions (Rule 8, Sec. 1) and after a momentary pause the Referee blows his whistle and moves his hand to start the action. Note—Some wrestlers watch the Referee's hand to get a fast start. It is usually better in such cases to blow the whistle a moment before moving the hand. The whistle starts the action. The hand signal is for the timers, in case they do not hear the whistle.

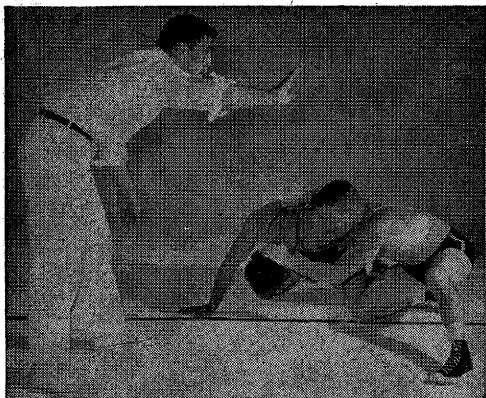

Fig. 5 (top left) STOPPING THE MATCH. The Referee blows his whistle and raises his hand to stop the match. The arm and hand are extended with the palm of the hand directed toward the officials' table.

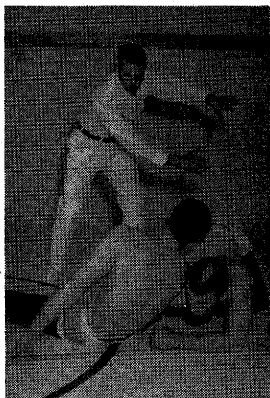

Fig. 6 (top right) STOPPING THE MATCH FOR OUT-OF-BOUNDS. When the contestants are out-of-bounds (Rule 8, Sec. 5) the Referee stops the match and extends both arms horizontally to the same side toward the out-of-bounds.

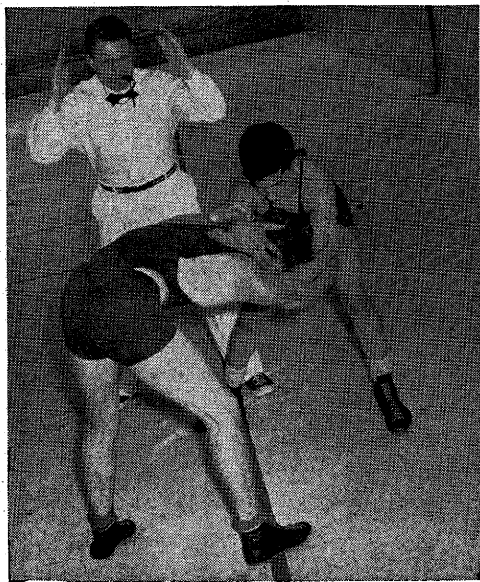

Fig. 7. (bottom left) DECLARING A NEUTRAL POSITION AFTER OUT-OF-BOUNDS. When the contestants are out-of-bounds (Rule 8, Sec. 5 and 5a) and neither is in an advantage position, the Referee stops the match as in Fig. 5 and signals a Neutral position. The upper arms are front horizontal, both forearms are vertical and the hands are extended upward. The Referee places himself in the most advantageous position to determine the out-of-bounds and stops the match immediately when the out-of-bounds occurs.

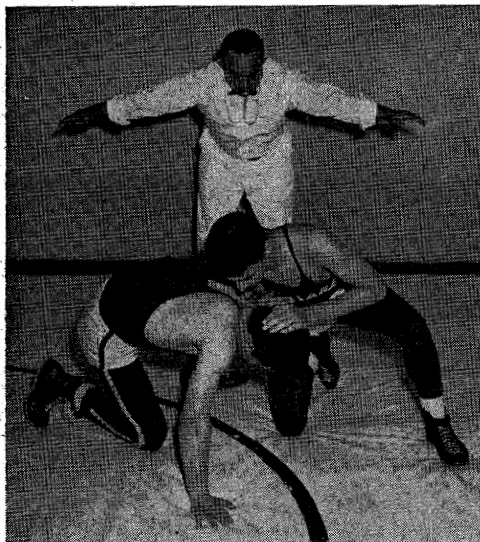
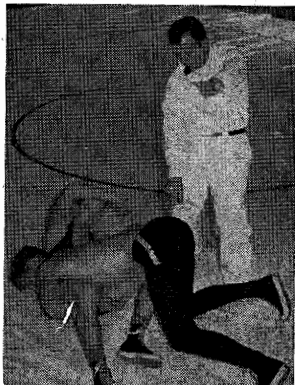

Fig. 8. (top left) INDICATING A NEUTRAL POSITION DURING A SCRIMMAGE FOR A TAKE-DOWN. Both arms are extended sideward slightly below the horizontal with the palms of the hands down. The Referee moves his hands back and forth bringing them together and moving them away while verbally announcing "no advantage."

Fig. 9. (bottom left) INDICATING RETENTION OF ADVANTAGE. Whenever there is any doubt as to the contestant in the advantage position the Referee should indicate the contestant in the advantage position by pointing to him with the index finger of one hand. The Referee will keep his other hand down and along his leg so that there will be no confusion as to whether any points are awarded.

Fig. 10. (bottom right) AWARDING POINTS. One arm and index finger are pointed at the wrestler receiving the points. At the same time the Referee verbally announces the award and the name of the team receiving it as he raises his opposite arm to a near vertical position, indicating with extended fingers the number of points awarded.



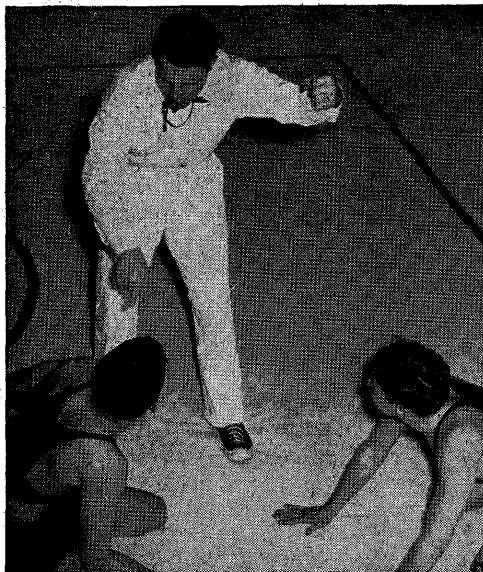

Fig. 11. (top left) **WARNING A CONTESTANT FOR A VIOLATION.** The match is stopped. The index finger of one hand is pointed to the violator. At the same time the Referee verbally announces the penalty and raises the opposite arm with his fist doubled to indicate the "warning" penalty.

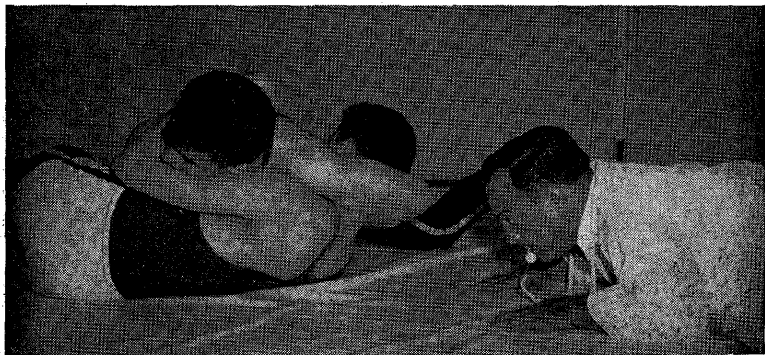

Fig. 12. (bottom) **SCORING A PINNING SITUATION.** The Referee gets down on the mat in a prone position for the best view of the defensive contestant's back while at the same time trying to keep out of the way of the contestants. The Referee does not signal a score for a "near-fall" or "predicament" until the pinning situation is ended. (Rule 8, Sec. 13, Note 1) After the situation is finished the Referee extends one arm upward indicating with the fingers the number of points awarded as he directs the index finger of his other hand toward the contestant receiving the points. (See Fig. 10.)

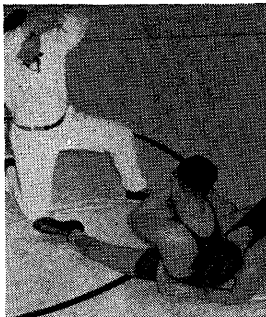

Fig. 13. (top left) **CALLING A FALL.** When the fall (Rule 8, Sec. 11) is imminent the Referee raises one hand about 10 inches. As soon as the fall is completed he quickly strikes the mat with the palm and verbally announces "Fall." The Referee is not to put his hands under the back of the defensive wrestler unless his view of the shoulders is blocked by one or both contestants and it is absolutely necessary for him to feel the back on the mat in order to call the fall (Rule 13, Sec. 14)

Fig. 14. (top right) **INTERLOCKING HANDS, Rule 10, Sec. 7a) OR GRASPING CLOTHING, (Rule 10, Sec. 7h) DURING AN ESCAPE MANEUVER** When the bottom contestant is in the process of an escape or reversal and the contestant on top locks his hands or grasps the clothing to prevent the maneuver, the Referee indicates the violation by grasping the wrist of one hand with his other hand and holding it over his head. This signal stops the advantage time for the top contestant, and indicates the violation has occurred but the Referee is allowing the bottom contestant an opportunity to complete the action providing he does so in one continuous maneuver. If the maneuver is successful (bottom contestant gains neutral or top position) The Referee signals the points and the match continues with no interruption. If the bottom contestant fails to complete the maneuver the Referee stops the match and awards the penalty. (See Penalty Chart)

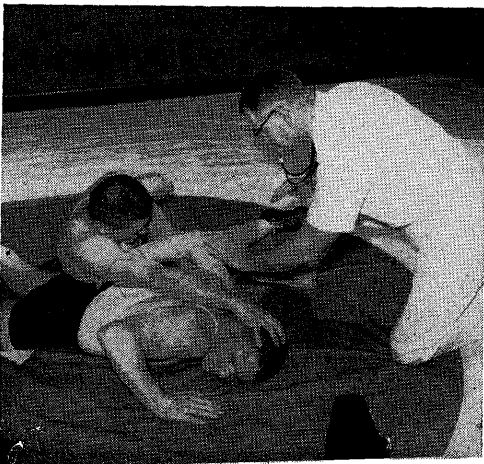

Fig. 15. (bottom left) **PREVENTING AN ILLEGAL OR POTENTIALLY DANGEROUS HOLD.** (Rule 10, Sec. 6 & Rule 13, Sec. 13) The Referee anticipates a potentially dangerous hold and gets in position to block it before it becomes dangerous. He may also verbally caution the contestant against forcing a potentially dangerous hold into an illegal hold.



Fig. 16. (top left) **CALLING TIME OUT.** The match is stopped as in Figure 5. If there is to be a delay in resuming the match, the Referee will indicate "time-out" by extending one hand in vertical position at right angles to his chest with the ends of the fingers touching the palm of the other hand which is extended in a horizontal position in front of the chest. The Referee announces to the scores the reason for the time out and to whom it is charged.

Fig. 17. (center right) **DECLARING THE WINNER.** (Rule 13, Sec. 17) At the end of the match the Referee orders the wrestlers to shake hands and raises the hand of the winner.



Fig. 18. (bottom left) **DECLARING A DRAW.** In case of a tie score at the end of the match in dual meets the Referee will raise a hand of each of the contestants after they shake hands.